

Luna

Ceiling hoist: Multiple solutions

The Luna ceiling hoist with its unique spherical shape and excellent functional features, is a true example of innovative Danish design.

Luna can be described as a fixed and portable ceiling hoist in one and the same unit, a truly unique feature. Changing Luna from fixed to portable mode, and vice versa, can be done within seconds by simply detaching and reattaching the unit to the track. No tools are needed. This unique two-in-one feature makes Luna the preferred ceiling hoist for care facilities as it provides a flexibility of choice, allowing the final decision of either fixed or portable unit to be made at a later point. This flexibility is a cost effective advantage for the institution.

Combine Luna with Ergolet's extensive programme of ceiling and wall mounted tracks, and you have a ceiling hoist system providing complete solutions to meet the latest requirements in the care sector.

Other features include Ergolet's patented spreader bar and sling hook system ensuring safe and simple sling attachment. And our comfortable ergonomic hand control, with its clear function buttons, is designed to help make patient transfer a safe and simple task for the carer.

Key standard functions

- Class leading state-of-the-art design and functionality.
- Weight capacity of 440 lbs and 660 lbs.
- Patented Ergolet sling hooks - simple and safe to use.
- Fixed or portable in a modular design.
- Charging through the ergonomic hand control and wall/table charger.
- Emergency lowering function.

Accessories

- Complete selection of 2, 3 and 4 point spreader bars to suit standard and bariatric needs.
- Complete range of slings
- Weigh scales



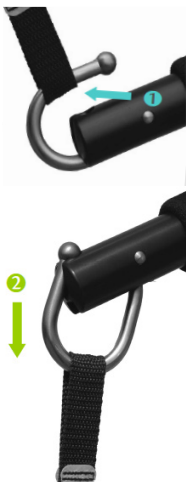

Sling attachment:
a minimum of downward pressure
locks the sling hook. Pull upwards
to unlock sling hook.



Mounts horizontally in a fixed or
portable mode without using tools.

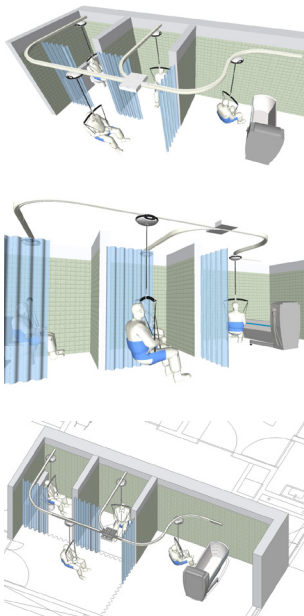

Room to room transfer.

Version	Item-number
Luna 440 lbs (white/grey)	015-01910 / 015-01912
Luna 660 lbs (white/grey)	015-01936 / 015-01937
Luna room to room 440 lbs (white)	015-01922
Luna room to room 660 lbs (grey)	015-01920

TECHNICAL SPECIFICATION

Max. capacity	440 lbs / 660 lbs
Length of lifting strap	86.6"
Weight	15 lbs w/o spreader bar
Measurements	12.6" x 5.1"
Battery operation	36 V, lead acid batteries
Charging	100 - 240 V, 0,5A.
Chassis	Aluminium
Housing	High impact, moulded ABS
Noise	Lwa during lifting/lowering without load is 49dB(A) Lwa during lifting/lowering at maximum load is 53dB(A)
Lifting speed down	1.7" mm/sec with 196 lbs load
Lifting speed up	1.2" mm/sec with 196 lbs load
No. of lifts per charge	50 lifts of 19.7" with 220 lbs
ISO	ISO 10535

- Soft start and stop motor control
- Electrical emergency lowering
- Electrical emergency stop
- Low battery indicator (visual LED)
- Charging indicators
- Power on indicators
- Overload protection
- Emergency brake system

Fixed

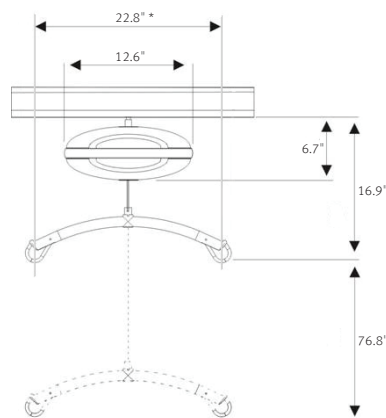

Portable

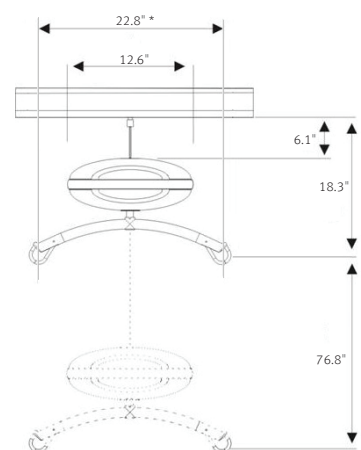

* The size of the spreader bar varies depending on the model.

Consult the Technical manual for further specifications. All figures and measurements are for guidance only and may differ in actual situations. Ergolet reserves the right to changes without notice.

Product photos may include accessories. Consult your dealer.



date 20.09.2012 - ver. 11

Ergolet
Taarnborgvej 12C
4220 Korsøer
Denmark
tel. +45 70 27 37 20
e-mail: ergolet@ergolet.dk



www.ergolet.com